

APPLICATION GUIDELINES

BARBED FITTING

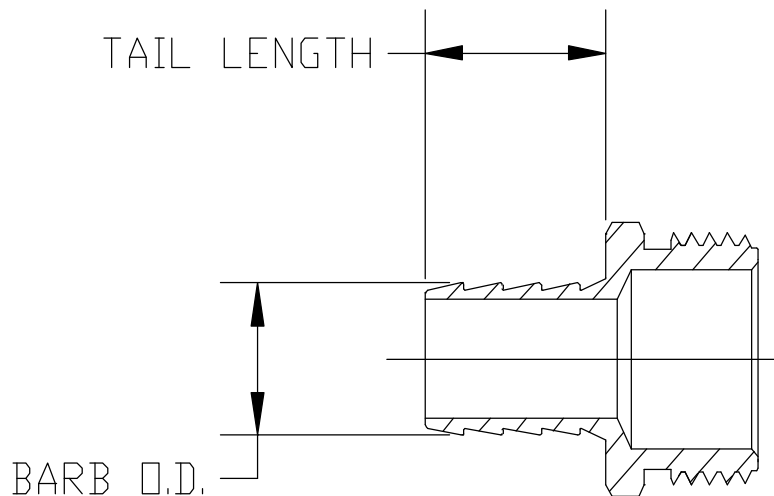

General information

The easy way to select the proper size barbed fitting for the hose is to measure the I.D. (inside diameter) of the hose. The correct size barb will be slightly larger, approximately .010" to .025", than the measured hose I.D.. This over sizing will vary depending on the hose composition. A snug fit will be created even before the compression is applied from the crimping of the smooth ferrule.