

APPLICATION GUIDELINES

SMOOTH FERRULE

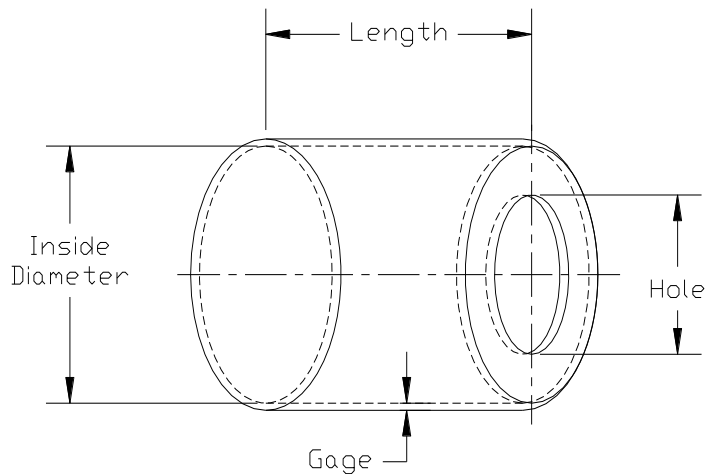

General Information

The easy way to select the proper size smooth ferrule is to insert the coupling tail into the hose, measure the hose O.D. (outside diameter) over the inserted tail, and add from .005" up to .025" to the measurement. That figure should be the approximate I.D. (inside diameter) of the ferrule. The hole in the ferrule must allow clearance for the coupling tail or the barb. The length of the ferrule should allow for .050" to .100" extension of the insert's tail beyond the end of the ferrule.